

4'-4" DECK HEIGHT ABOVE RAIL IS MEASURED AT CENTER OF CARBODY, INCLUDING CAMBER, WITH A LOAD EQUAL TO 50% OF LOAD LIMIT UNIFORMLY DISTRIBUTED OVER FULL LENGTH OF LOAD DECK.

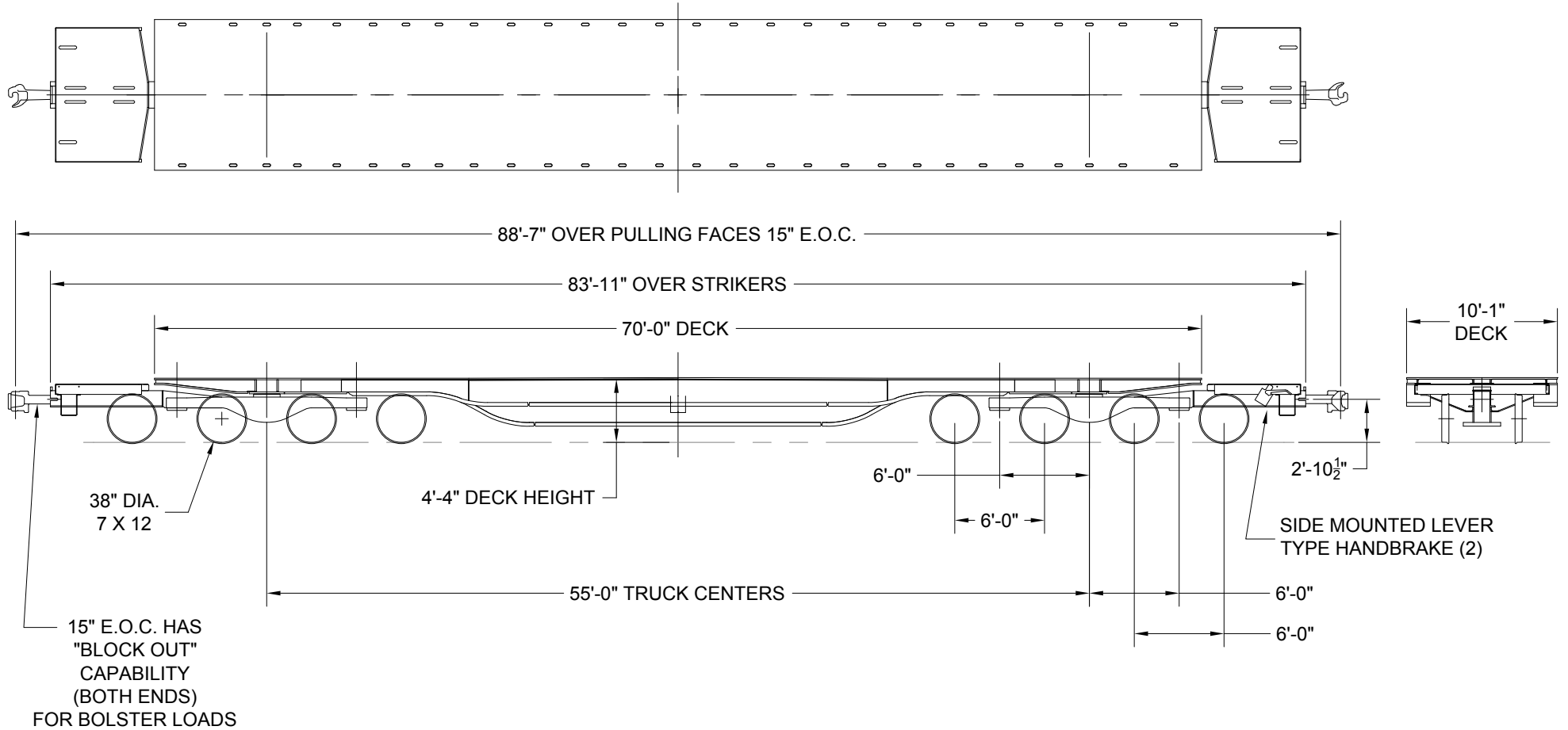

CAR WILL CARRY A CONCENTRATED LOAD AT THE CENTER OF THE CAR EQUAL TO THE LOAD LIMIT

CENTER OF GRAVITY - EMPTY = 34" ATR  
CLEARANCE PROFILE WITHIN AAR PLATE "C"

CAR SERIES	AVERAGE LOAD LIMIT LBS.	AVERAGE LIGHT WEIGHT LBS.
131250-131259	459,100	170,900
131365-131429	456,000	174,000

CAR NUMBERS QTTX 131250-131259  
CAR NUMBERS QTTX 131365-131429

<b>TTX</b>		TTX COMPANY CHICAGO, ILLINOIS	
230 TON, 70 FOOT DECK FLAT CAR			
CLASS SSH70 & JSH70	DATE 06-01-02	REV J	11007