

4'-5 $\frac{1}{2}$ " DECK HEIGHT ABOVE RAIL IS MEASURED AT CENTER OF CARBODY, INCLUDING CAMBER, WITH A LOAD EQUAL TO 50% OF LOAD LIMIT UNIFORMLY DISTRIBUTED OVER FULL LENGTH OF LOAD DECK.

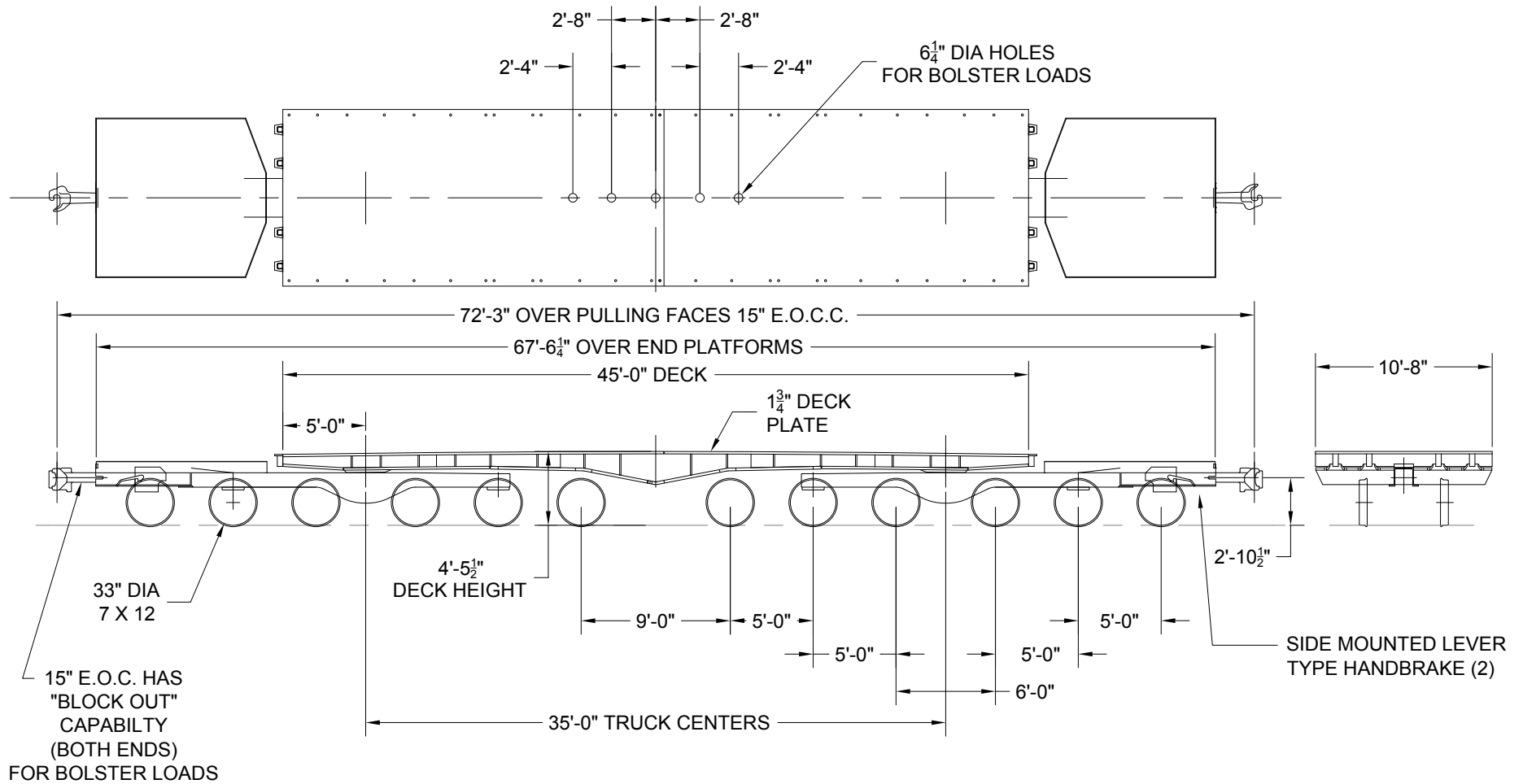

CAR WILL CARRY A CONCENTRATED LOAD AT THE CENTER OF THE CAR EQUAL TO THE LOAD LIMIT

CENTER OF GRAVITY - EMPTY = 32" ATR  
CLEARANCE PROFILE WITHIN AAR PLATE "B"

CAR NUMBER	LOAD LIMIT LBS.	LIGHT WEIGHT LBS.
131100	735,000	210,000
131101	737,600	207,400
131102	738,900	206,100
131103	738,400	206,600
AVERAGE	737,500	207,500

CAR NUMBERS QTTX 131100-131103

<b>TTX</b>		TTX COMPANY CHICAGO, ILLINOIS	
370 TON, 45 FOOT DECK FLAT CAR			
CLASS NSH45	DATE 03-31-97	REV H	8693