

2'-6" DECK HEIGHT ABOVE RAIL IS MEASURED AT CENTER OF CARBODY, INCLUDING CAMBER, WITH A LOAD EQUAL TO 50% OF LOAD LIMIT UNIFORMLY DISTRIBUTED OVER FULL LENGTH OF LOAD DECK.

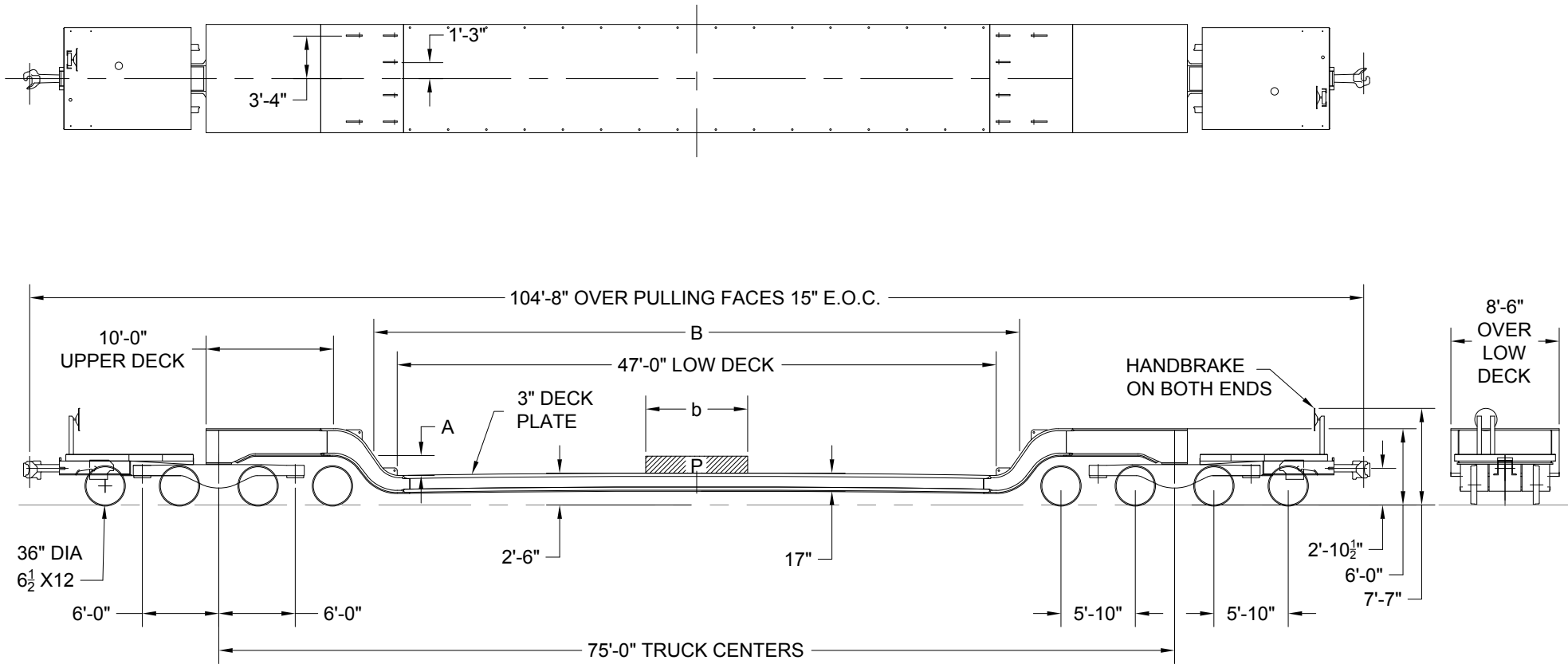

BOTTOM OF LOAD ABOVE DECK A	MAX. LENGTH OF LOAD B
12"	49'-10"
18"	50'-8"
24"	51'-4"

CAR WILL CARRY A CONCENTRATED LOAD AT THE CENTER OF THE CAR EQUAL TO THE LOAD LIMIT

CENTER OF GRAVITY - EMPTY = 27.5" ATR  
 CLEARANCE PROFILE EXCEEDS AAR PLATE "C-1" BY 7" AT UNDERSIDE OF 3" TOP DECK

CAR NUMBER	LOAD LIMIT LBS.	LIGHT WEIGHT LBS.
130500	297,900	228,100
130501	298,000	228,000
AVERAGE	298,000	228,000

CAR NUMBERS QTTX 130500-130501

**TTX** TTX COMPANY  
 CHICAGO, ILLINOIS

150 TON, 47 FOOT DECK  
 DEPRESSED CENTER FLAT CAR

CLASS IDH47	DATE 08-04-92	REV G	7222
----------------	------------------	----------	------